

The Heart Of *Faucets*

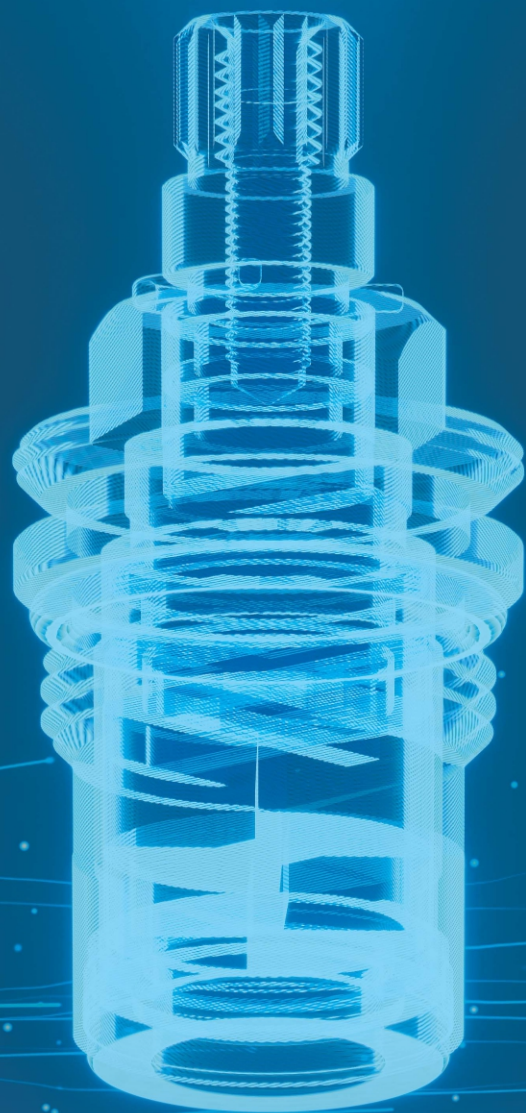

The Heart Of *Faucets*



Faucets
Cartridge



Atman Products, Survey No. 65/1/1, Plot No. 6, Ganesh Estate, Nr Varun Casting, Pardi-Padavala Rod, At: Lothada, Dist. Rajkot, Gujarat, India - 360024.

Mo.: +91 88498 03429

www.atmanproduct.com

atmanproducts1@gmail.com



Company

Profile

Your **Trusted**
Faucets **Cartridge**
Partner!

Welcome to **Atman Products**, where we have perfected the art of crafting exceptional faucet cartridges. As a leading manufacturer in the industry, we take immense pride in our commitment to delivering the finest quality and innovation. We understand that even the smallest component, like a faucet cartridge, can make a significant difference in your daily life. That's why we pour our passion and expertise into creating precision-engineered cartridges that ensure a seamless water flow, precise temperature control, and a leak-free operation, turning ordinary faucets into extraordinary ones.

OUR **Mission**

We're on a mission to perfect every drop with our meticulously crafted faucet cartridges, ensuring smooth water flow and leak-free performance.

OUR **Vision**

We envision a future where every faucet equipped with an Atman cartridge delivers a flawless water experience, contributing to water conservation and customer satisfaction. Through continuous research and customer-centricity, we strive to become the most trusted and sought-after brand in faucet cartridges, enriching lives one drop at a time.



Manufacturing Process

Work Flow

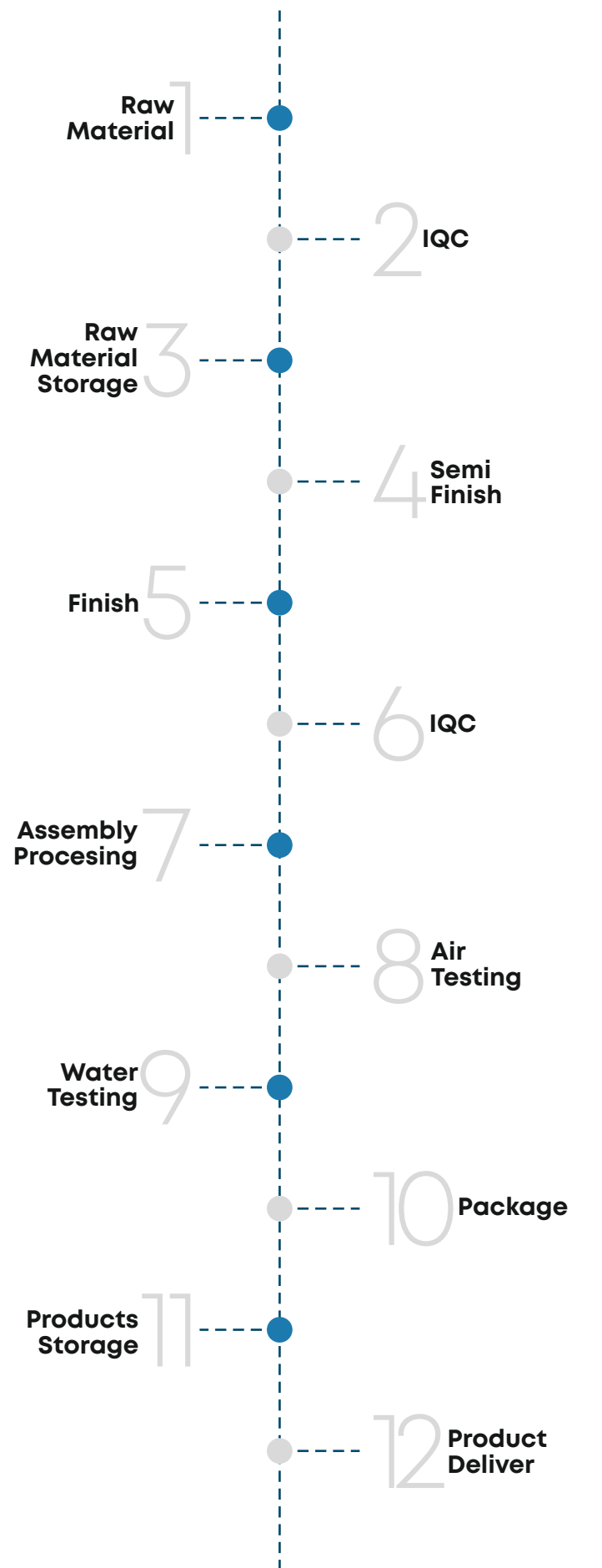

We Work For Quality

The Heart Of *Faucets*

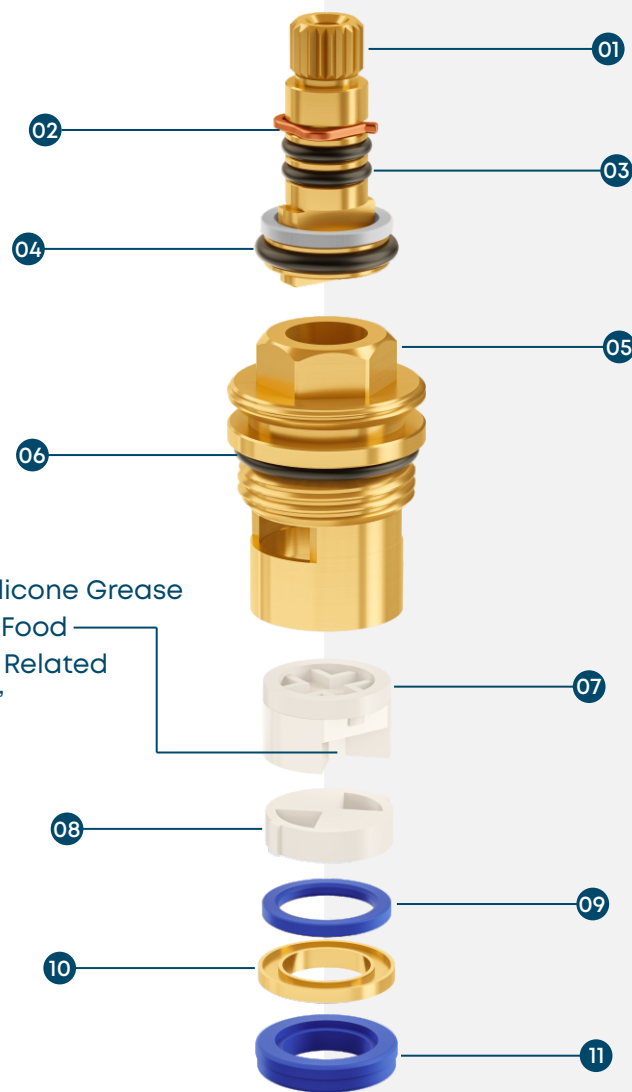

"Imported Silicone Grease
Which Meet Food
Standards & Related
Certificates."

No.	Component	Material Description
01	Lever	Hpb59-3
02	Garter Spring	QSn6.5-01
03	O Ring Gasket	EPDM
04	Lubricating O-Washer	POM
05	Brass Housing	Hpb59-3
06	O Ring Gasket	EPDM
07	Moving Disc	AL203>96%
08	Fixed Disc	AL203>96%
09	Sealing Gasket	Silicone
10	Base	Hpb59-3
11	Sealing Gasket	Silicone

Table Of Content

Your
Start Journey
Hear!

08	AT0102 1/2" Quarter Turn Brass Cartridge	18	AT0301 3/4" Quarter Turn Brass Cartridge
09	AT0103 1/2" Quarter Turn Brass Cartridge	19	AT0303 3/4" Quarter Turn Brass Cartridge
10	AT0104 1/2" Quarter Turn Brass Cartridge	20	AT0305 3/4" Quarter Turn Brass Cartridge
11	AT0601 1/2" Quarter Turn Brass Cartridge	21	AT0701 3/4" Quarter Turn Brass Concealed Cartridge
12	AT0202 1/2" Quarter Turn Brass Concealed Cartridge	22	AT0705 3/4" Quarter Turn Brass Concealed Cartridge
13	AT0204 1/2" Quarter Turn Brass Concealed Cartridge	23	AT0401 M28X1.5 Quarter Turn Brass Cartridge
14	AT0501 M22X1.5 Quarter Turn Brass Cartridge	24	AT0402 M28X1.5 Quarter Turn Brass Cartridge
15	AT0502 M22X1.5 Quarter Turn Brass Cartridge	25	AT0801 M28X1.5 Quarter Turn Brass Concealed Cartridge
16	AT0901 M22X1.5 Quarter Turn Brass Concealed Cartridge	26	AT0802 M28X1.5 Quarter Turn Brass Concealed Cartridge
17	AT0902 M22X1.5 Quarter Turn Brass Concealed Cartridge	27	AT1001 M28X1.5 Quarter Turn Brass Concealed Cartridge

AT0102

1/2" Quarter Turn Brass Cartridge



Technical Data	
Max. Turning angle	90°
Switching Torque	0.08-0.15N.m
Brass Composition Code	HPB59-3
Temp.	3-90°C
Connection Thread	G1/2"
Bursting Test	35 Kg/cm2
Lifetime Test	>500000 Open and Close Cycles

100% High Air Pressure Testing On Every Cartridges Before Dispatch

AT0103

1/2" Quarter Turn Brass Cartridge



Technical Data	
Max. Turning angle	90°
Switching Torque	0.08-0.15N.m
Brass Composition Code	HPB59-3
Temp.	3-90°C
Connection Thread	G1/2"
Bursting Test	35 Kg/cm2
Lifetime Test	>500000 Open and Close Cycles

100% High Air Pressure Testing On Every Cartridges Before Dispatch

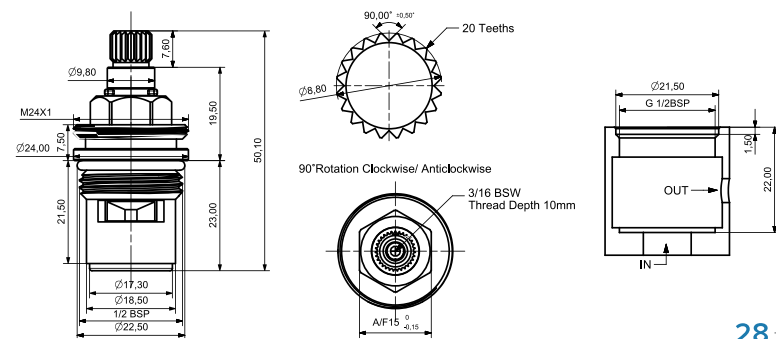

Static Pressure (kg/cm2)		Dynamic Pressure (kg/cm2)
High Pressure	Low Pressure	
8	0.2	3

Ceramic Disc	
Material	97% AL2O3
Hardness	≥1050Hv5
Flatness	≤0.6μm
Roughness	≤Ra0.25μm

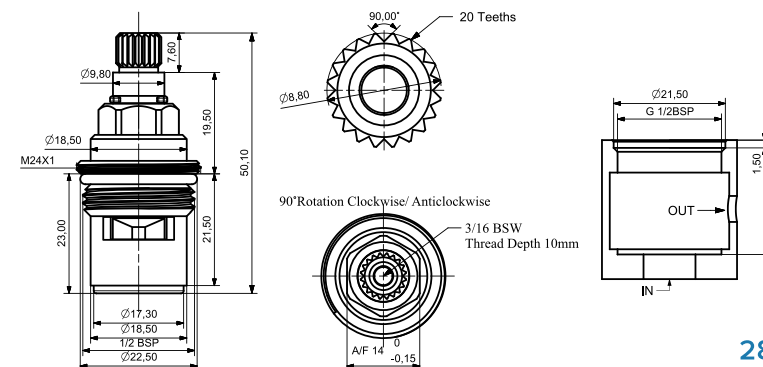
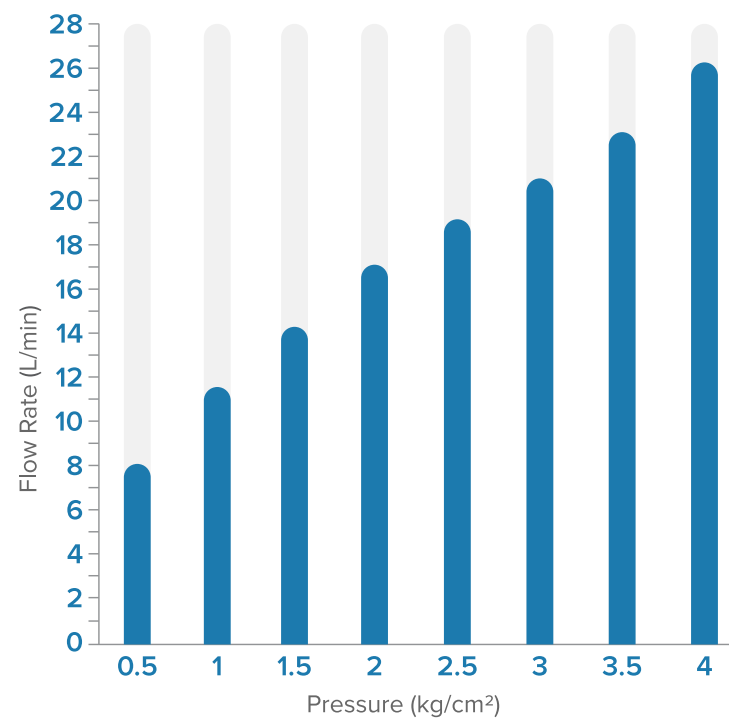

Static Pressure (kg/cm2)		Dynamic Pressure (kg/cm2)
High Pressure	Low Pressure	
8	0.2	3

Ceramic Disc	
Material	97% AL2O3
Hardness	≥1050Hv5
Flatness	≤0.6μm
Roughness	≤Ra0.25μm

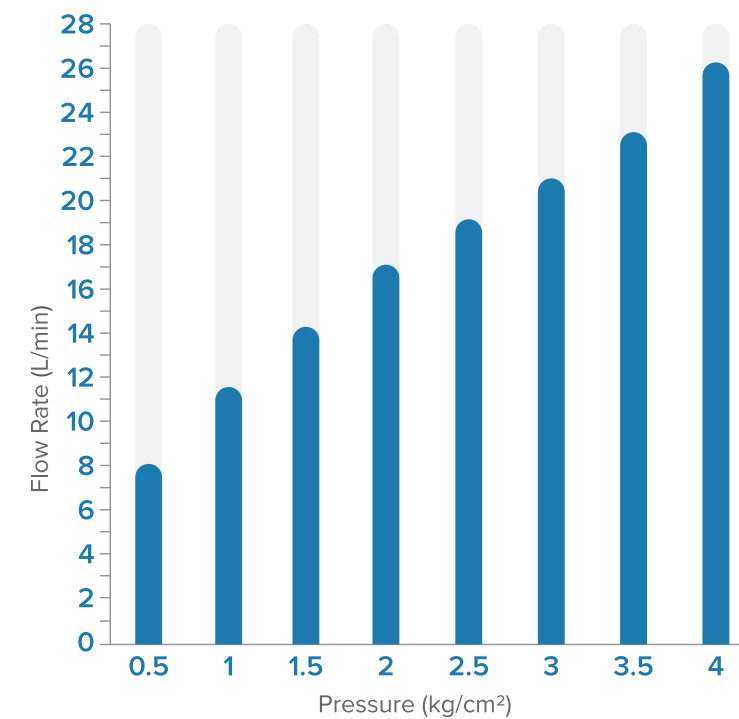

AT0104

1/2" Quarter Turn Brass Cartridge

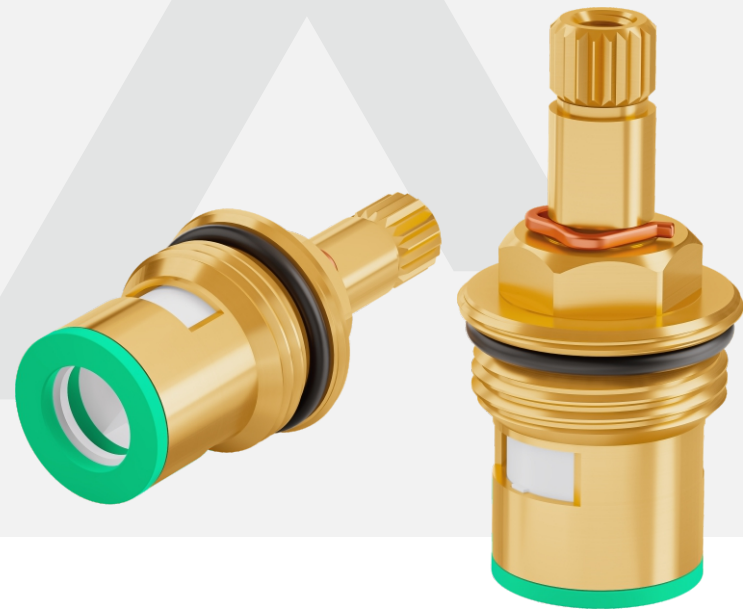

Technical Data	
Max. Turning angle	90°
Switching Torque	0.08-0.15N.m
Brass Composition Code	HPB59-3
Temp.	3-90°C
Connection Thread	G1/2"
Bursting Test	35 Kg/cm2
Lifetime Test	>200000 Open and Close Cycles

100% High Air Pressure Testing On Every Cartridges Before Dispatch

AT0601

1/2" Quarter Turn Brass Cartridge

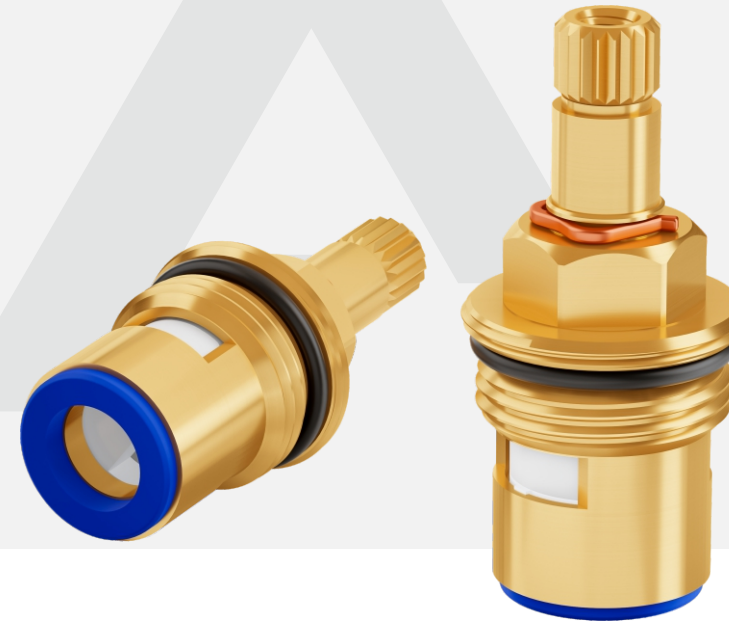

Technical Data	
Max. Turning angle	90°
Switching Torque	0.08-0.15N.m
Brass Composition Code	HPB59-3
Temp.	3-90°C
Connection Thread	G1/2"
Bursting Test	35 Kg/cm2
Lifetime Test	>500000 Open and Close Cycles

100% High Air Pressure Testing On Every Cartridges Before Dispatch

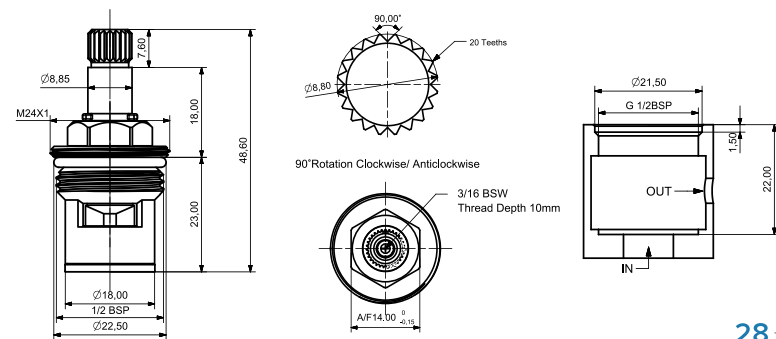

Static Pressure (kg/cm2)		Dynamic Pressure (kg/cm2)
High Pressure	Low Pressure	
8	0.2	3

Ceramic Disc	
Material	97% AL2O3
Hardness	≥1050Hv5
Flatness	≤0.6μm
Roughness	≤Ra0.25μm

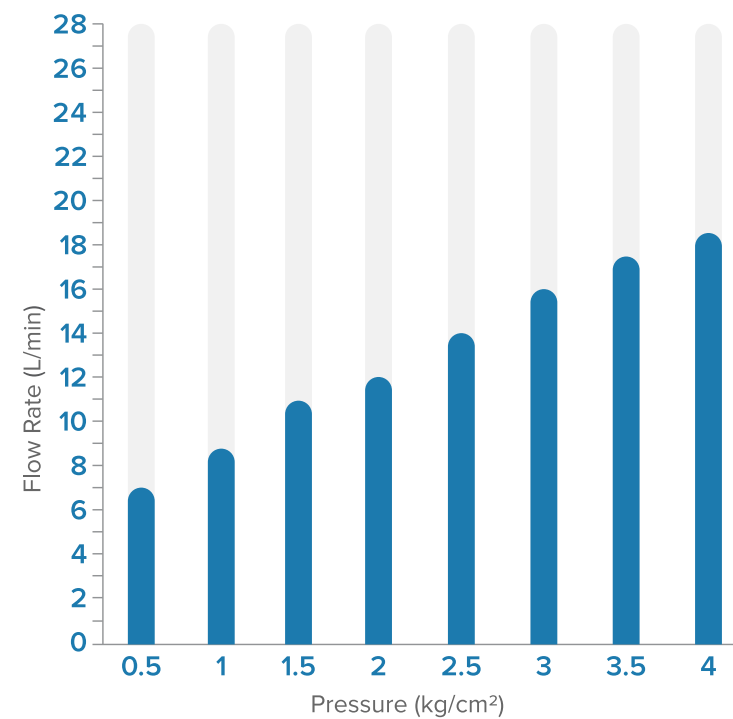

Water Flow Test	
Pressure (Bar)	Flow Rate (L/min)
0.5	7
1	8.8
1.5	10.9
2	12.1
2.5	14.2
3	16
3.5	17.5
4	18.5

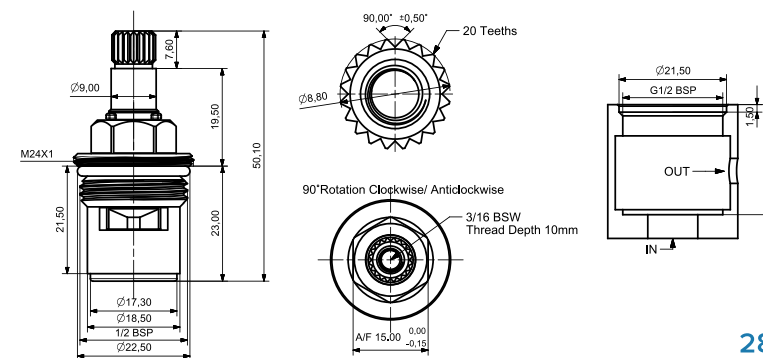

Static Pressure (kg/cm2)		Dynamic Pressure (kg/cm2)
High Pressure	Low Pressure	
8	0.2	3

Ceramic Disc	
Material	97% AL2O3
Hardness	≥1050Hv5
Flatness	≤0.6μm
Roughness	≤Ra0.25μm

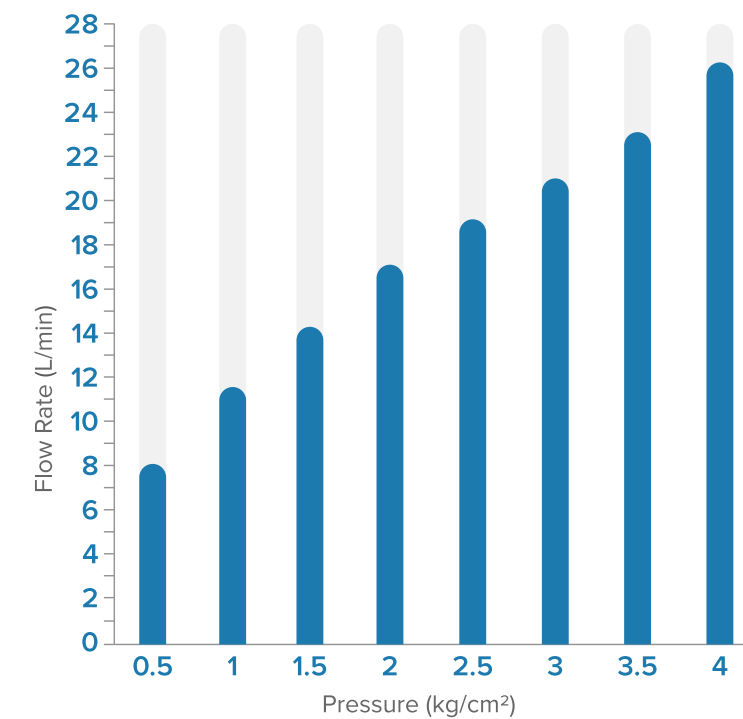

Water Flow Test	
Pressure (Bar)	Flow Rate (L/min)
0.5	7.8
1	11.4
1.5	14.2
2	17
2.5	19.1
3	21
3.5	23.1
4	26.3

AT0202

1/2" Quarter Turn Brass Concealed Cartridge



Technical Data	
Max. Turning angle	90°
Switching Torque	0.08-0.15N.m
Brass Composition Code	HPB59-3
Temp.	3-90°C
Connection Thread	G1/2"
Bursting Test	35 Kg/cm2
Lifetime Test	>200000 Open and Close Cycles

100% High Air Pressure Testing On Every Cartridges Before Dispatch

AT0204

1/2" Quarter Turn Brass Concealed Cartridge



Technical Data	
Max. Turning angle	90°
Switching Torque	0.08-0.15N.m
Brass Composition Code	HPB59-3
Temp.	3-90°C
Connection Thread	G1/2"
Bursting Test	35 Kg/cm2
Lifetime Test	>500000 Open and Close Cycles

100% High Air Pressure Testing On Every Cartridges Before Dispatch

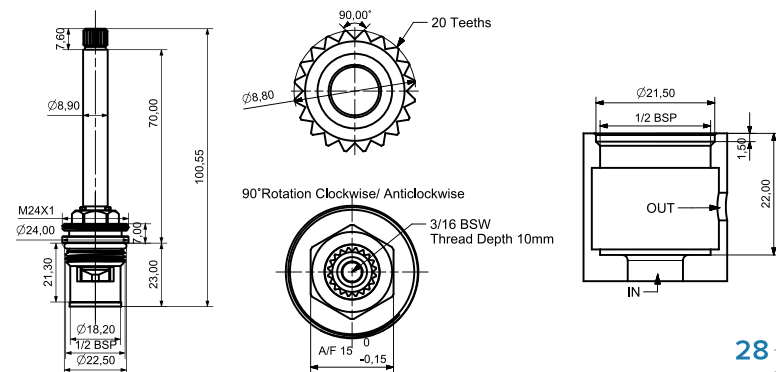

Static Pressure (kg/cm2)		Dynamic Pressure (kg/cm2)
High Pressure	Low Pressure	
8	0.2	3

Ceramic Disc	
Material	97% AL2O3
Hardness	≥1050Hv5
Flatness	≤0.6μm
Roughness	≤Ra0.25μm

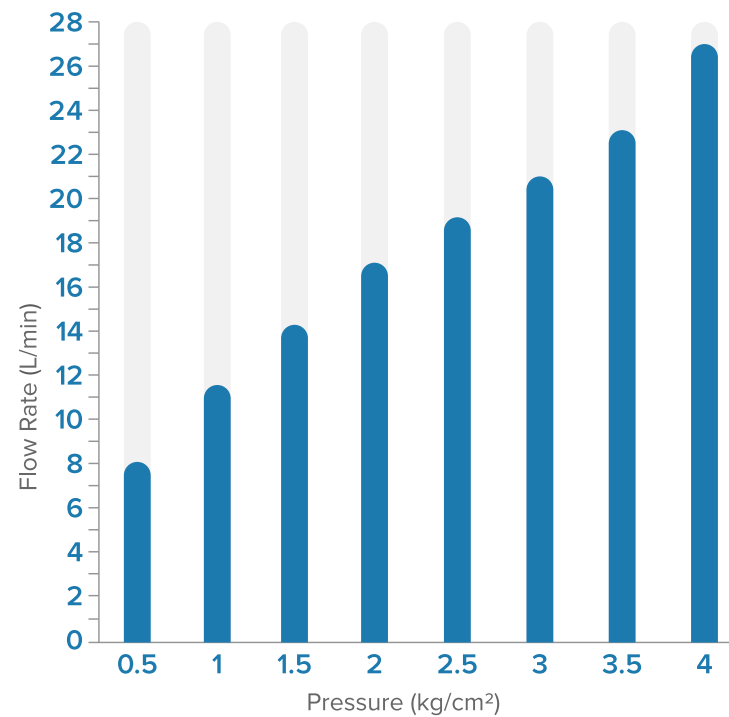

Water Flow Test	
Pressure (Bar)	Flow Rate (L/min)
0.5	8.1
1	11.8
1.5	14.4
2	17.8
2.5	19.6
3	21.3
3.5	23.7
4	27

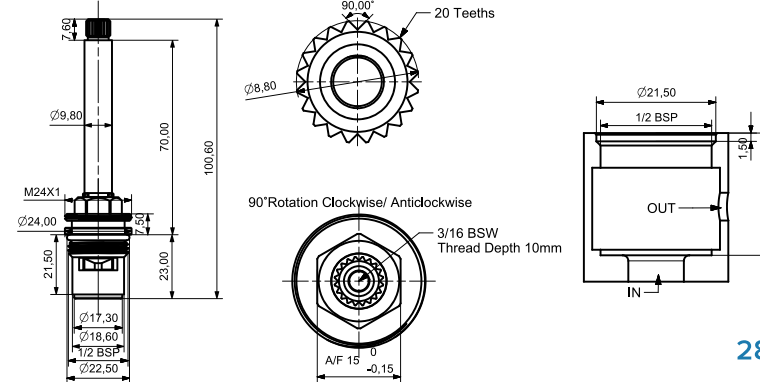

Static Pressure (kg/cm2)		Dynamic Pressure (kg/cm2)
High Pressure	Low Pressure	
8	0.2	3

Ceramic Disc	
Material	97% AL2O3
Hardness	≥1050Hv5
Flatness	≤0.6μm
Roughness	≤Ra0.25μm

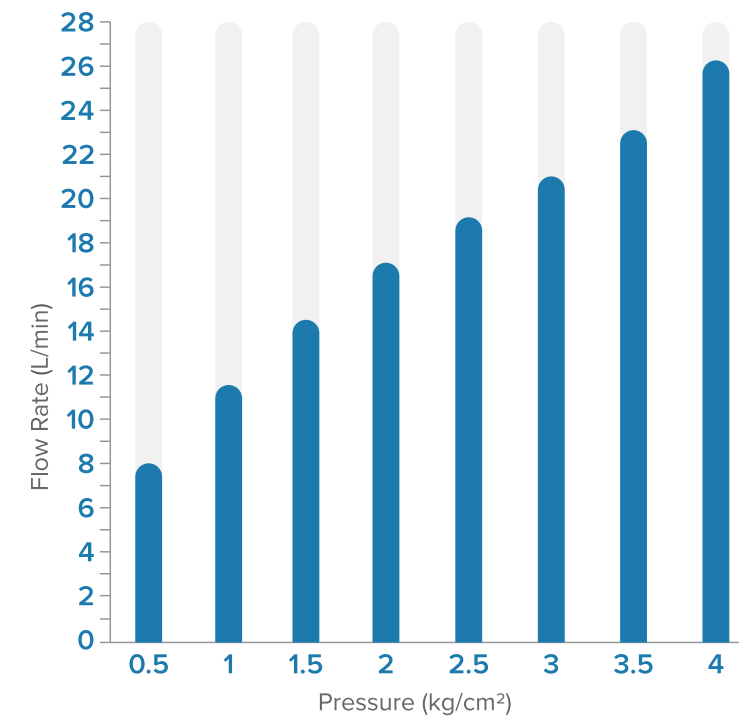

Water Flow Test	
Pressure (Bar)	Flow Rate (L/min)
0.5	8
1	11.7
1.5	14.5
2	17.3
2.5	19.5
3	21.4
3.5	23.5
4	26.7

AT0501

M22X1.5 Quarter Turn Brass Cartridge



Technical Data	
Max. Turning angle	90°
Switching Torque	0.08-0.15N.m
Brass Composition Code	HPB59-3
Temp.	3-90°C
Connection Thread	M22X1.5
Bursting Test	35 Kg/cm2
Lifetime Test	>500000 Open and Close Cycles

100% High Air Pressure Testing On Every Cartridges Before Dispatch

AT0502

M22X1.5 Quarter Turn Brass Cartridge



Technical Data	
Max. Turning angle	90°
Switching Torque	0.08-0.15N.m
Brass Composition Code	HPB59-3
Temp.	3-90°C
Connection Thread	M22X1.5
Bursting Test	35 Kg/cm2
Lifetime Test	>500000 Open and Close Cycles

100% High Air Pressure Testing On Every Cartridges Before Dispatch

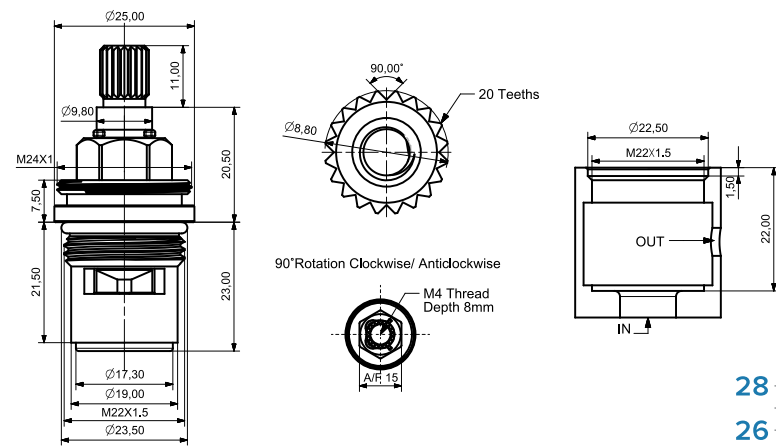

Static Pressure (kg/cm2)		Dynamic Pressure (kg/cm2)
High Pressure	Low Pressure	
8	0.2	3

Ceramic Disc	
Material	97% AL2O3
Hardness	≥1050Hv5
Flatness	≤0.6μm
Roughness	≤Ra0.25μm

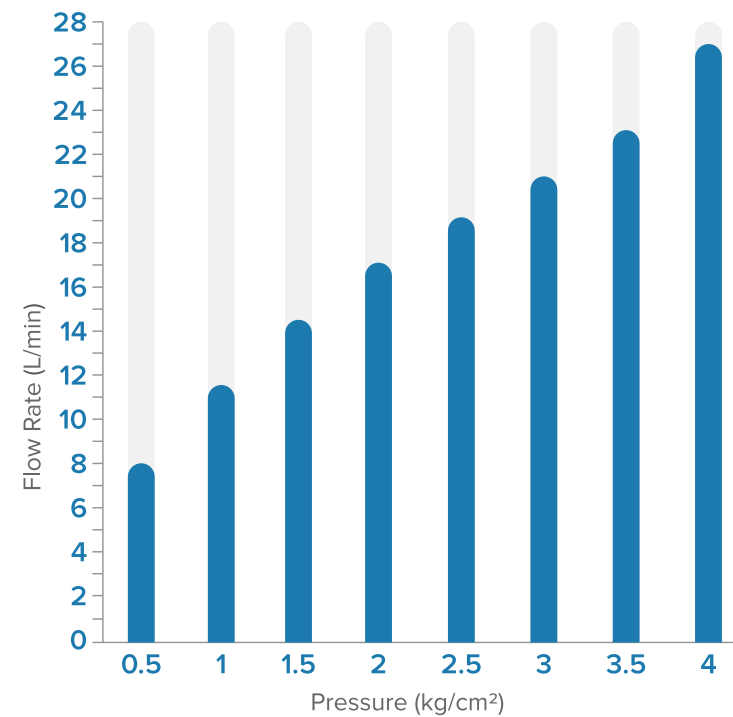

Water Flow Test	
Pressure (Bar)	Flow Rate (L/min)
0.5	8
1	11.8
1.5	14.5
2	17.5
2.5	19.7
3	21.6
3.5	23.6
4	27.2

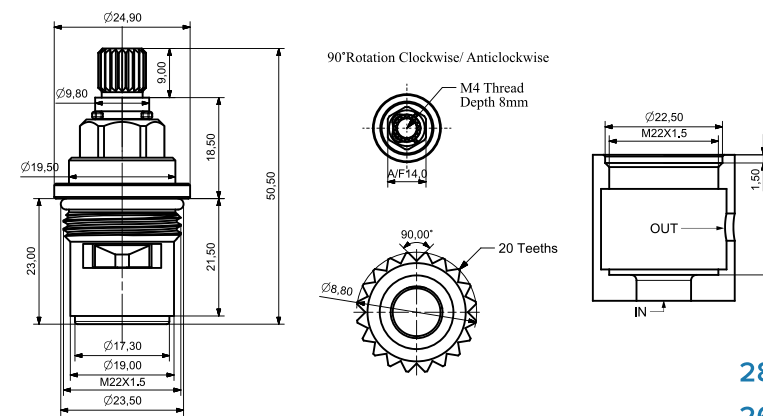

Static Pressure (kg/cm2)		Dynamic Pressure (kg/cm2)
High Pressure	Low Pressure	
8	0.2	3

Ceramic Disc	
Material	97% AL2O3
Hardness	≥1050Hv5
Flatness	≤0.6μm
Roughness	≤Ra0.25μm

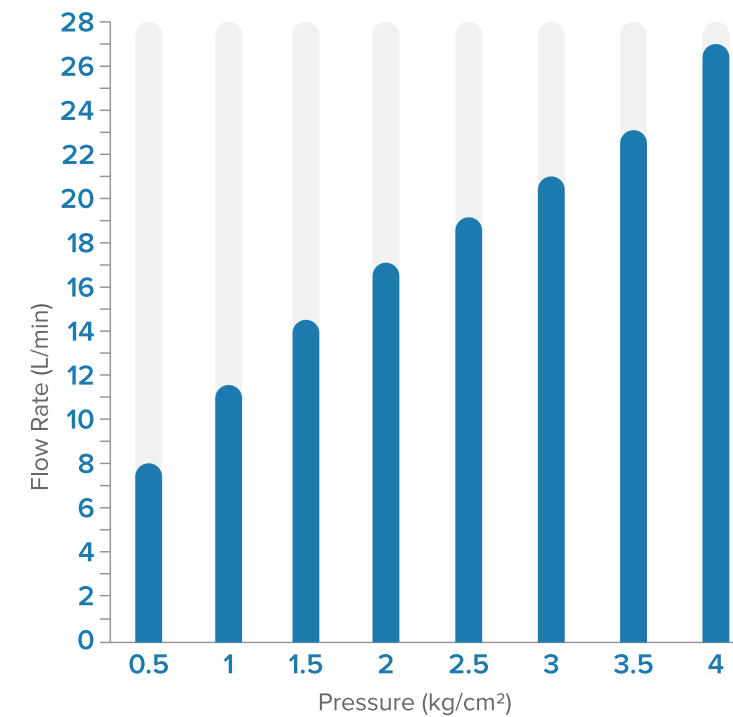

Water Flow Test	
Pressure (Bar)	Flow Rate (L/min)
0.5	8
1	11.8
1.5	14.5
2	17.5
2.5	19.7
3	21.6
3.5	23.6
4	27.2

AT0901

M22X1.5 Quarter Turn Brass Concealed Cartridge



Technical Data	
Max. Turning angle	90°
Switching Torque	0.08-0.15N.m
Brass Composition Code	HPB59-3
Temp.	3-90°C
Connection Thread	M22X1.5
Bursting Test	35 Kg/cm2
Lifetime Test	>200000 Open and Close Cycles

100% High Air Pressure Testing On Every Cartridges Before Dispatch

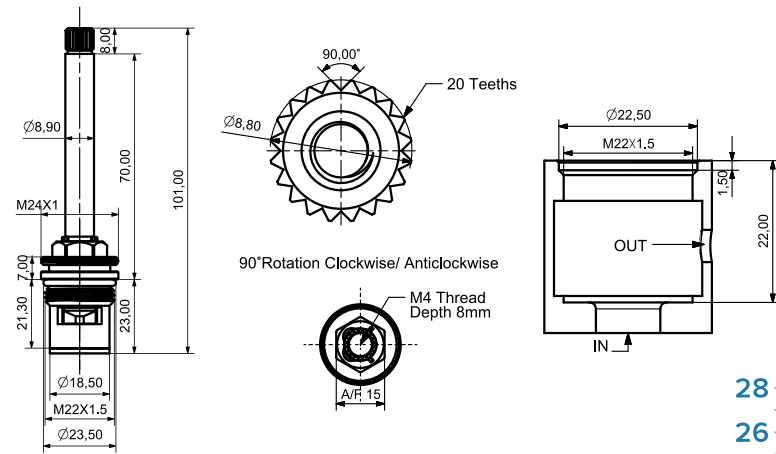

Static Pressure (kg/cm2)		Dynamic Pressure (kg/cm2)
High Pressure	Low Pressure	
8	0.2	3

Ceramic Disc	
Material	97% AL2O3
Hardness	≥1050Hv5
Flatness	≤0.6μm
Roughness	≤Ra0.25μm

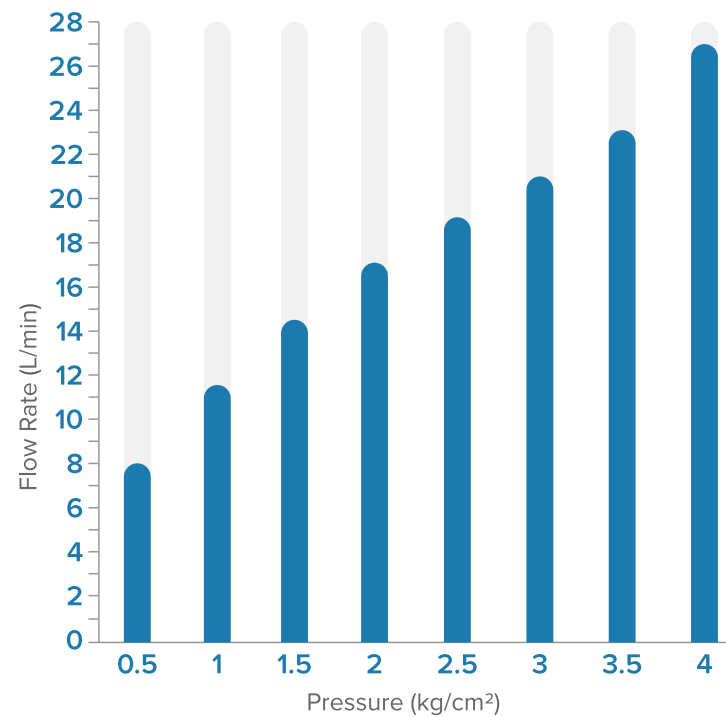

Water Flow Test	
Pressure (Bar)	Flow Rate (L/min)
0.5	8
1	11.8
1.5	14.5
2	17.5
2.5	19.7
3	21.6
3.5	23.6
4	27.2

AT0902

M22X1.5 Quarter Turn Brass Concealed Cartridge



Technical Data	
Max. Turning angle	90°
Switching Torque	0.08-0.15N.m
Brass Composition Code	HPB59-3
Temp.	3-90°C
Connection Thread	M22X1.5
Bursting Test	35 Kg/cm2
Lifetime Test	>500000 Open and Close Cycles

100% High Air Pressure Testing On Every Cartridges Before Dispatch

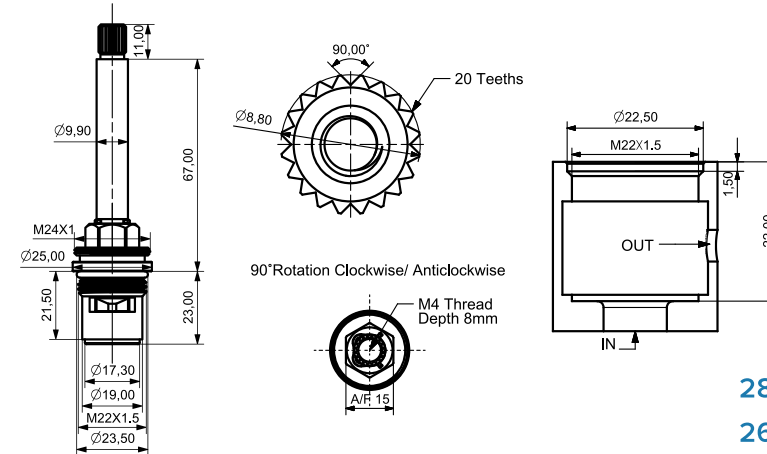

Static Pressure (kg/cm2)		Dynamic Pressure (kg/cm2)
High Pressure	Low Pressure	
8	0.2	3

Ceramic Disc	
Material	97% AL2O3
Hardness	≥1050Hv5
Flatness	≤0.6μm
Roughness	≤Ra0.25μm

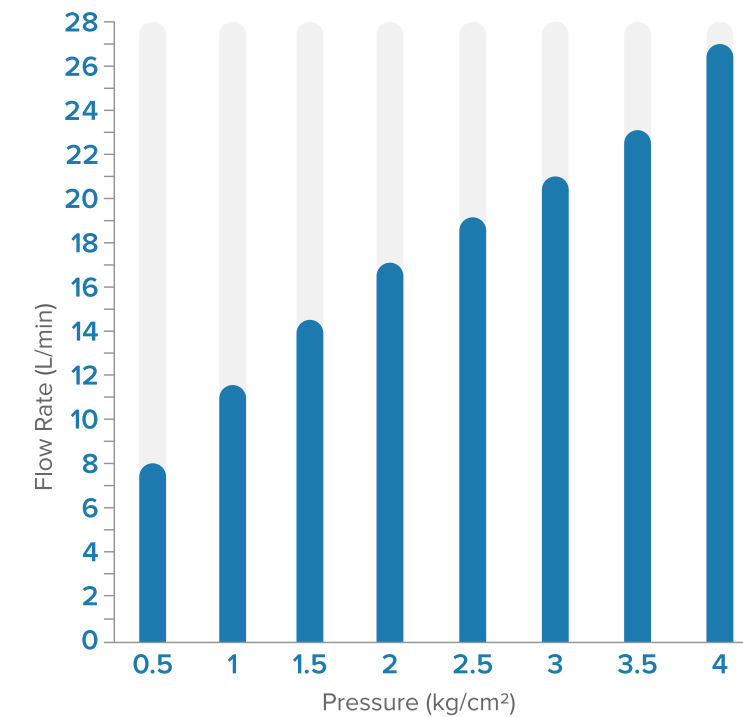

Water Flow Test	
Pressure (Bar)	Flow Rate (L/min)
0.5	8
1	11.8
1.5	14.5
2	17.5
2.5	19.7
3	21.6
3.5	23.6
4	27.2

AT0301

3/4" Quarter Turn Brass Cartridge

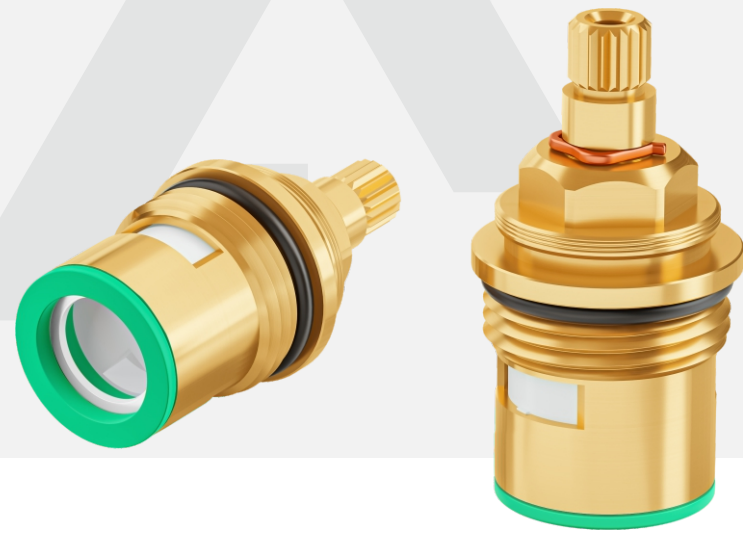

Technical Data	
Max. Turning angle	90°
Switching Torque	0.08-0.15N.m
Brass Composition Code	HPB59-3
Temp.	3-90°C
Connection Thread	G3/4"
Bursting Test	35 Kg/cm2
Lifetime Test	>200000 Open and Close Cycles

100% High Air Pressure Testing On Every Cartridges Before Dispatch

AT0303

3/4" Quarter Turn Brass Cartridge



Technical Data	
Max. Turning angle	90°
Switching Torque	0.08-0.15N.m
Brass Composition Code	HPB59-3
Temp.	3-90°C
Connection Thread	G3/4"
Bursting Test	35 Kg/cm2
Lifetime Test	>500000 Open and Close Cycles

100% High Air Pressure Testing On Every Cartridges Before Dispatch

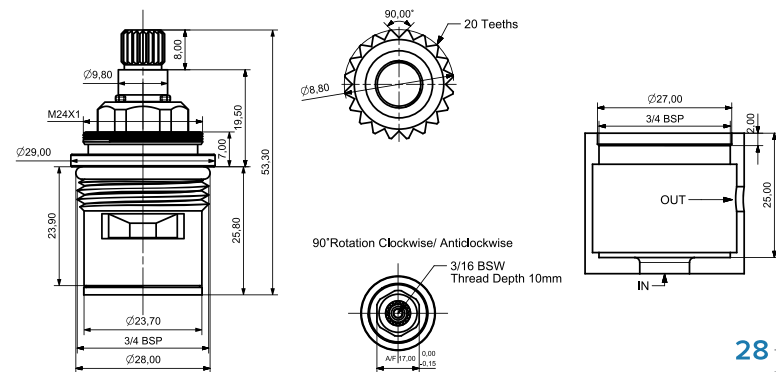

Static Pressure (kg/cm2)		Dynamic Pressure (kg/cm2)
High Pressure	Low Pressure	
8	0.2	3

Ceramic Disc	
Material	97% AL2O3
Hardness	≥1050Hv5
Flatness	≤0.6μm
Roughness	≤Ra0.25μm

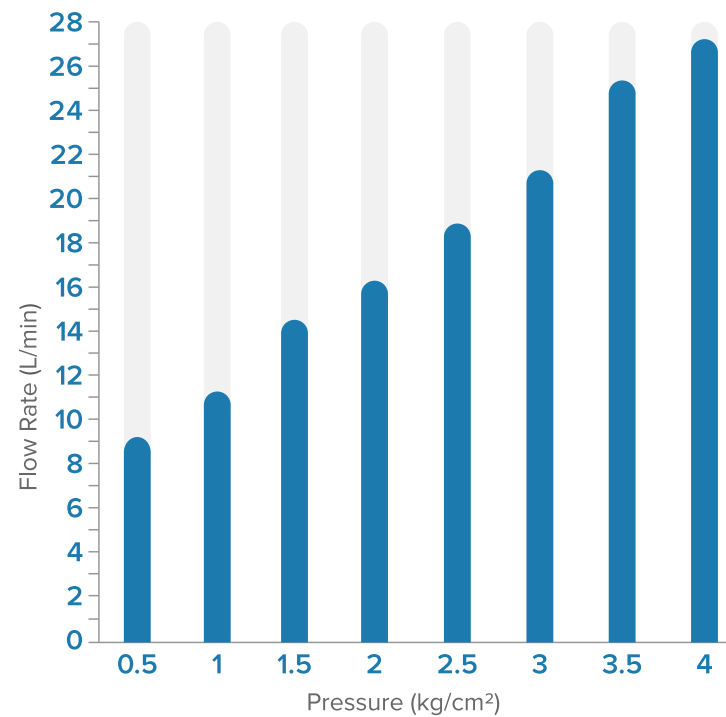

Water Flow Test	
Pressure (Bar)	Flow Rate (L/min)
0.5	9.2
1	13.2
1.5	16.3
2	18.9
2.5	21.3
3	23.4
3.5	25.4
4	27.2

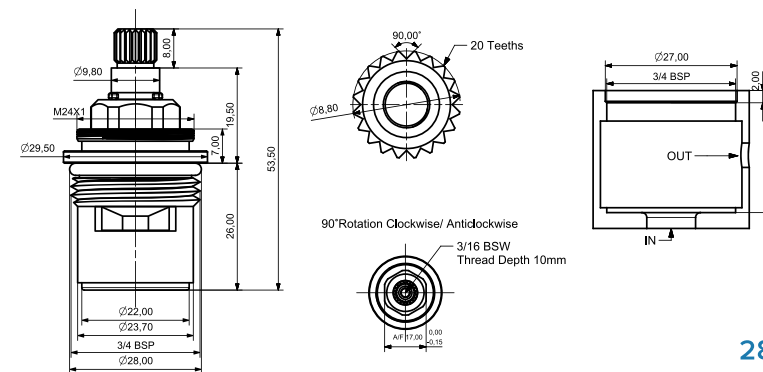

Static Pressure (kg/cm2)		Dynamic Pressure (kg/cm2)
High Pressure	Low Pressure	
8	0.2	3

Ceramic Disc	
Material	97% AL2O3
Hardness	≥1050Hv5
Flatness	≤0.6μm
Roughness	≤Ra0.25μm

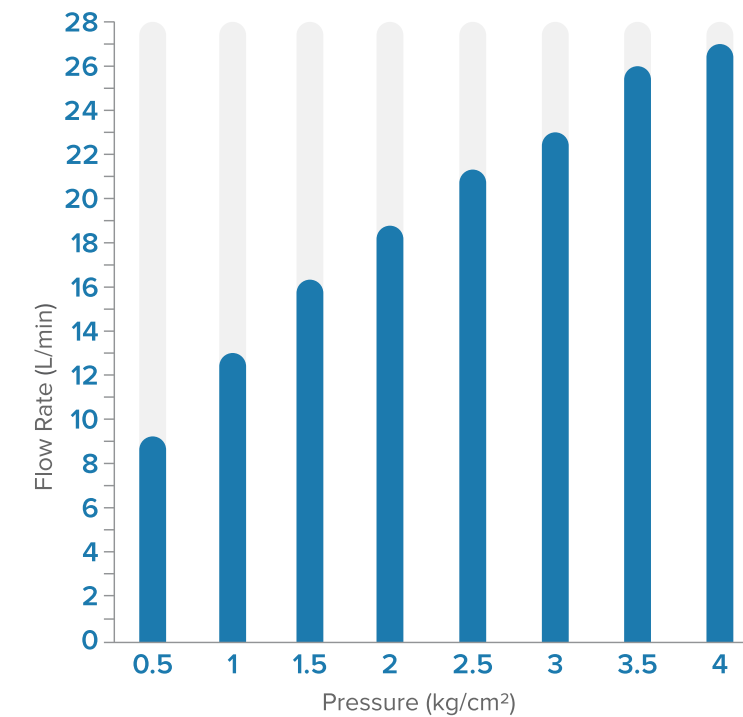

Water Flow Test	
Pressure (Bar)	Flow Rate (L/min)
0.5	9.1
1	13
1.5	16.2
2	18.8
2.5	21.2
3	23.2
3.5	25.3
4	27

AT0305

3/4" Quarter Turn Brass Cartridge

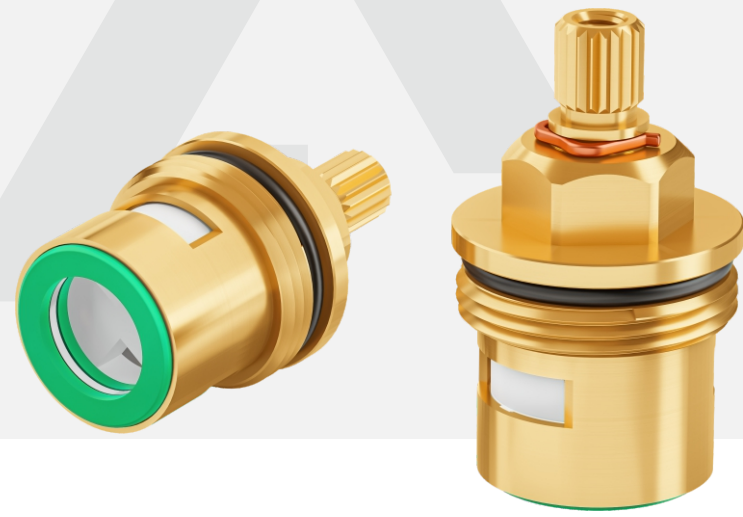

Technical Data	
Max. Turning angle	90°
Switching Torque	0.08-0.15N.m
Brass Composition Code	HPB59-3
Temp.	3-90°C
Connection Thread	G3/4"
Bursting Test	35 Kg/cm2
Lifetime Test	>200000 Open and Close Cycles

100% High Air Pressure Testing On Every Cartridges Before Dispatch

AT0701

3/4" Quarter Turn Brass Concealed Cartridge



Technical Data	
Max. Turning angle	90°
Switching Torque	0.08-0.15N.m
Brass Composition Code	HPB59-3
Temp.	3-90°C
Connection Thread	G3/4"
Bursting Test	35 Kg/cm2
Lifetime Test	>500000 Open and Close Cycles

100% High Air Pressure Testing On Every Cartridges Before Dispatch

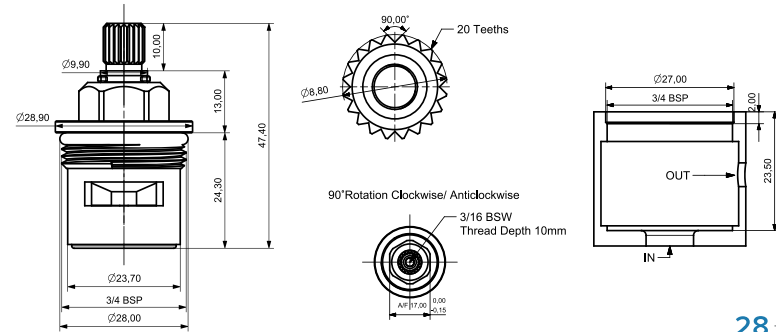

Static Pressure (kg/cm2)		Dynamic Pressure (kg/cm2)
High Pressure	Low Pressure	
8	0.2	3

Ceramic Disc	
Material	97% AL2O3
Hardness	≥1050Hv5
Flatness	≤0.6µm
Roughness	≤Ra0.25µm

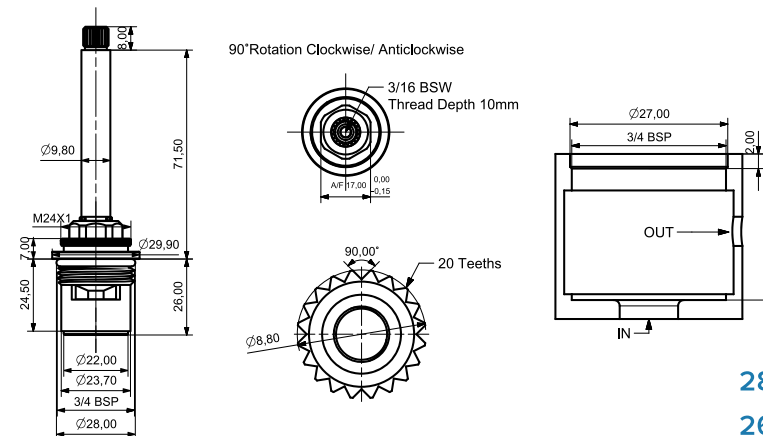

Static Pressure (kg/cm2)		Dynamic Pressure (kg/cm2)
High Pressure	Low Pressure	
8	0.2	3

Ceramic Disc	
Material	97% AL2O3
Hardness	≥1050Hv5
Flatness	≤0.6µm
Roughness	≤Ra0.25µm

Water Flow Test	
Pressure (Bar)	Flow Rate (L/min)
0.5	9.2
1	13.2
1.5	16.3
2	18.9
2.5	21.3
3	23.4
3.5	25.4
4	27.4

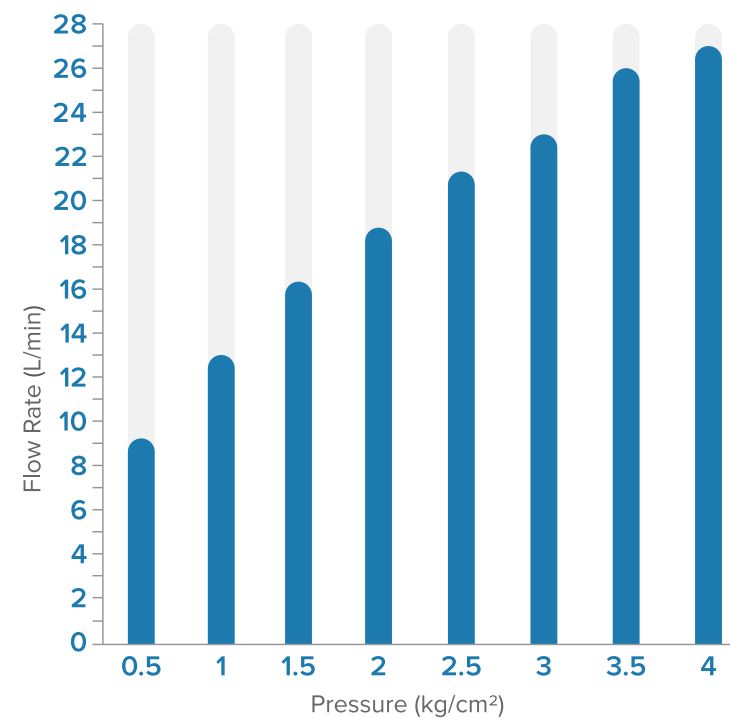

Water Flow Test	
Pressure (Bar)	Flow Rate (L/min)
0.5	9.3
1	13.2
1.5	16.5
2	19
2.5	21.4
3	23.4
3.5	26.6
4	27.3

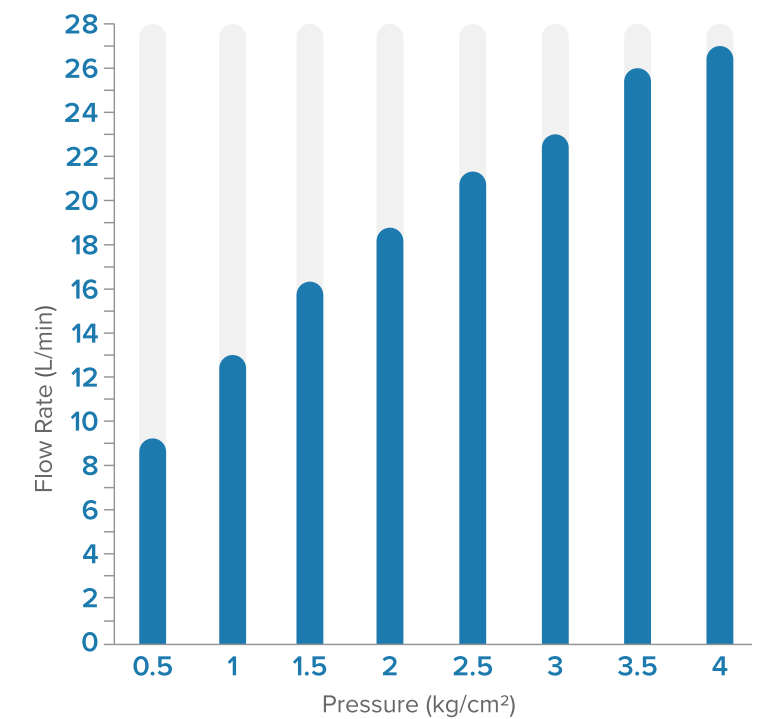

AT0705

3/4" Quarter Turn Brass Concealed Cartridge



Technical Data	
Max. Turning angle	90°
Switching Torque	0.08-0.15N.m
Brass Composition Code	HPB59-3
Temp.	3-90°C
Connection Thread	G3/4"
Bursting Test	35 Kg/cm2
Lifetime Test	>200000 Open and Close Cycles

100% High Air Pressure Testing On Every Cartridges Before Dispatch

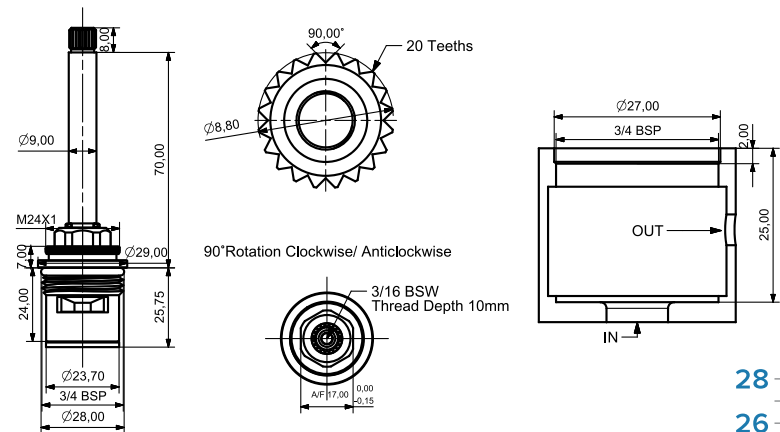

Static Pressure (kg/cm2)		Dynamic Pressure (kg/cm2)
High Pressure	Low Pressure	
8	0.2	3

Ceramic Disc	
Material	97% AL2O3
Hardness	≥1050Hv5
Flatness	≤0.6μm
Roughness	≤Ra0.25μm

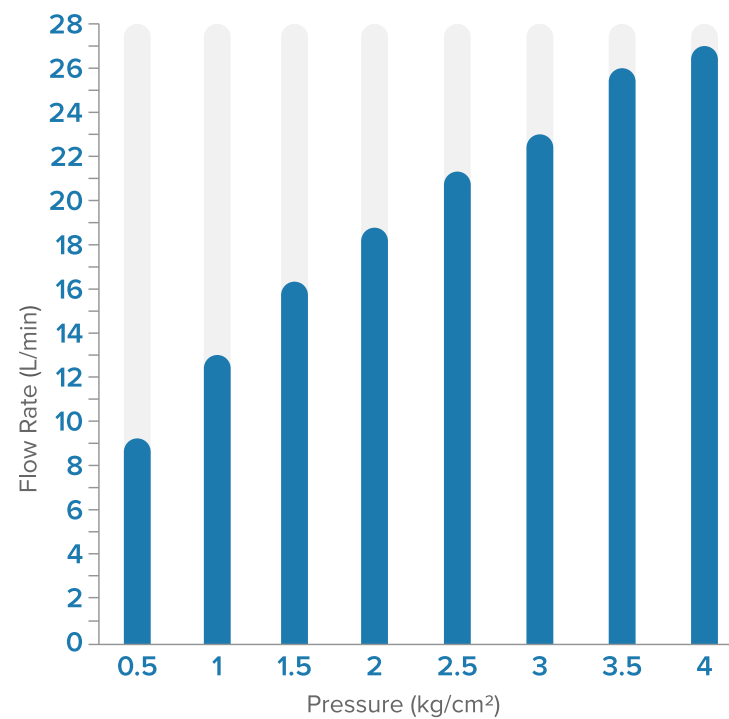

Water Flow Test	
Pressure (Bar)	Flow Rate (L/min)
0.5	9.3
1	13.3
1.5	16.5
2	18.9
2.5	21.4
3	23.4
3.5	25.8
4	27.4

AT0401

M28X1.5 Quarter Turn Brass Cartridge



Technical Data	
Max. Turning angle	90°
Switching Torque	0.08-0.15N.m
Brass Composition Code	HPB59-3
Temp.	3-90°C
Connection Thread	M28x1.5
Bursting Test	35 Kg/cm2
Lifetime Test	>500000 Open and Close Cycles

100% High Air Pressure Testing On Every Cartridges Before Dispatch

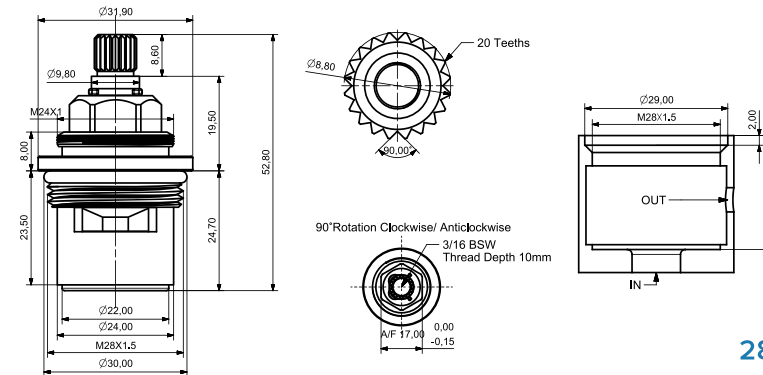

Static Pressure (kg/cm2)		Dynamic Pressure (kg/cm2)
High Pressure	Low Pressure	
8	0.2	3

Ceramic Disc	
Material	97% AL2O3
Hardness	≥1050Hv5
Flatness	≤0.6μm
Roughness	≤Ra0.25μm

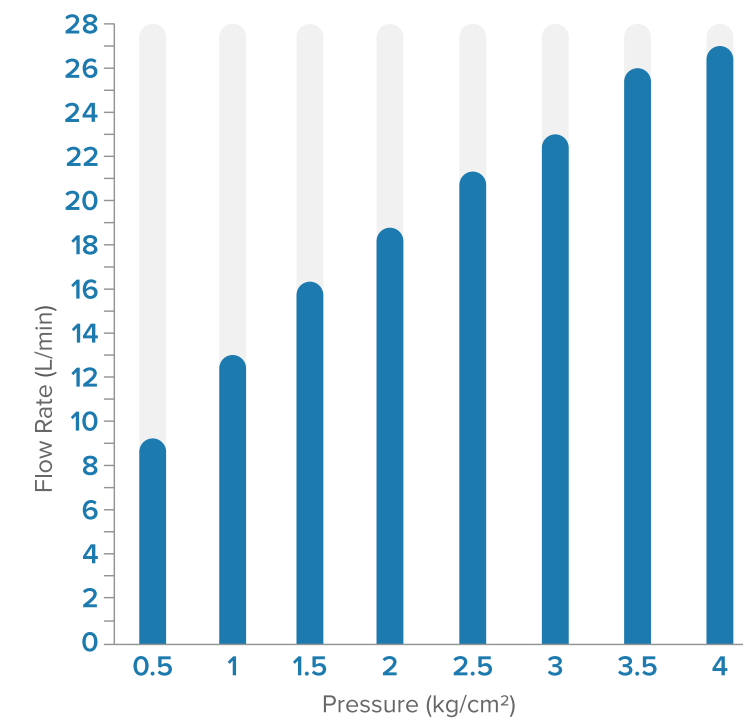

Water Flow Test	
Pressure (Bar)	Flow Rate (L/min)
0.5	9.1
1	13
1.5	16.2
2	18.8
2.5	21.2
3	23.2
3.5	25.3
4	27

AT0402

M28X1.5 Quarter Turn Brass Cartridge



Technical Data	
Max. Turning angle	90°
Switching Torque	0.08-0.15N.m
Brass Composition Code	HPB59-3
Temp.	3-90°C
Connection Thread	M28x1.5
Bursting Test	35 Kg/cm2
Lifetime Test	>500000 Open and Close Cycles

100% High Air Pressure Testing On Every Cartridges Before Dispatch

AT0801

M28X1.5 Quarter Turn Brass Concealed Cartridge



Technical Data	
Max. Turning angle	90°
Switching Torque	0.08-0.15N.m
Brass Composition Code	HPB59-3
Temp.	3-90°C
Connection Thread	M28x1.5
Bursting Test	35 Kg/cm2
Lifetime Test	>200000 Open and Close Cycles

100% High Air Pressure Testing On Every Cartridges Before Dispatch

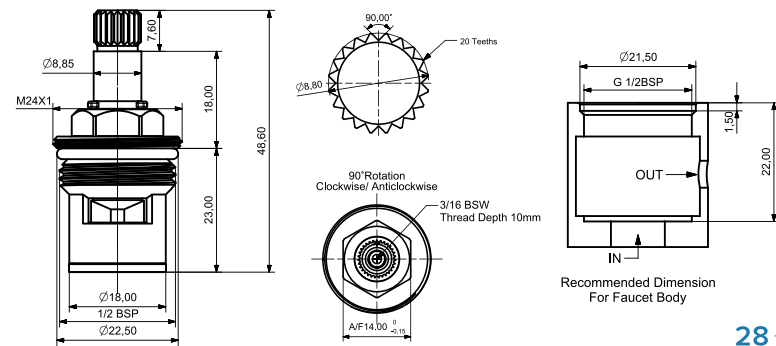

Static Pressure (kg/cm2)		Dynamic Pressure (kg/cm2)
High Pressure	Low Pressure	
8	0.2	3

Ceramic Disc	
Material	97% AL2O3
Hardness	≥1050Hv5
Flatness	≤0.6μm
Roughness	≤Ra0.25μm

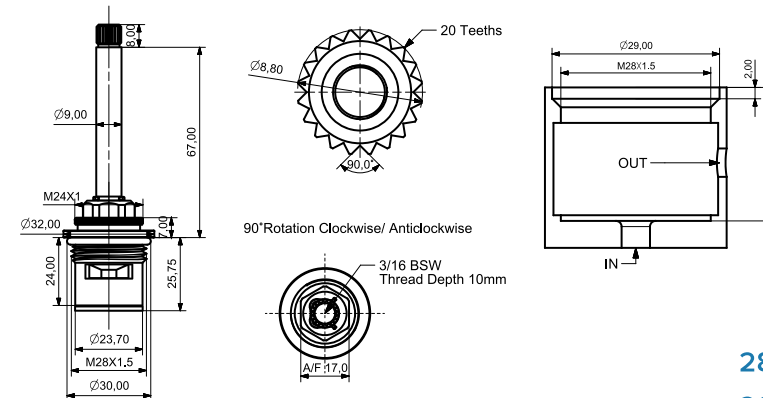
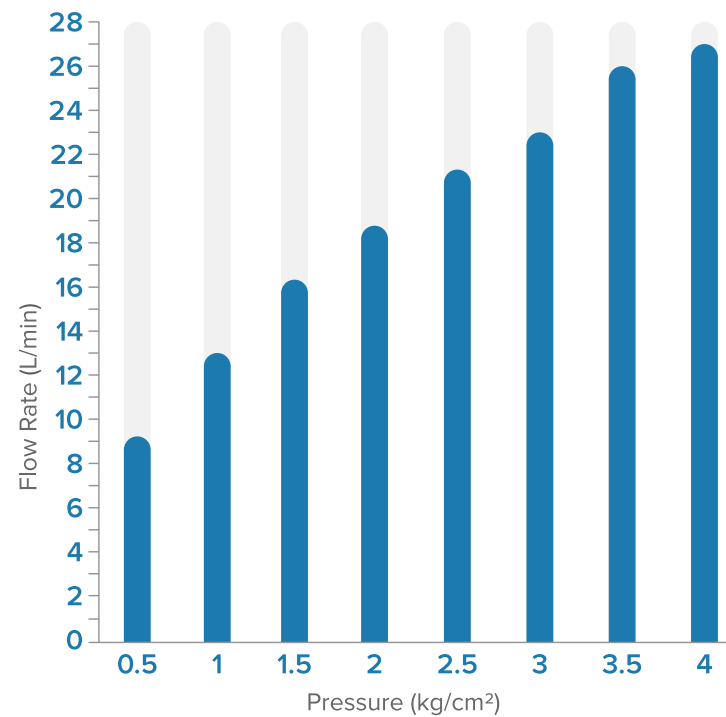

Static Pressure (kg/cm2)		Dynamic Pressure (kg/cm2)
High Pressure	Low Pressure	
8	0.2	3

Ceramic Disc	
Material	97% AL2O3
Hardness	≥1050Hv5
Flatness	≤0.6μm
Roughness	≤Ra0.25μm

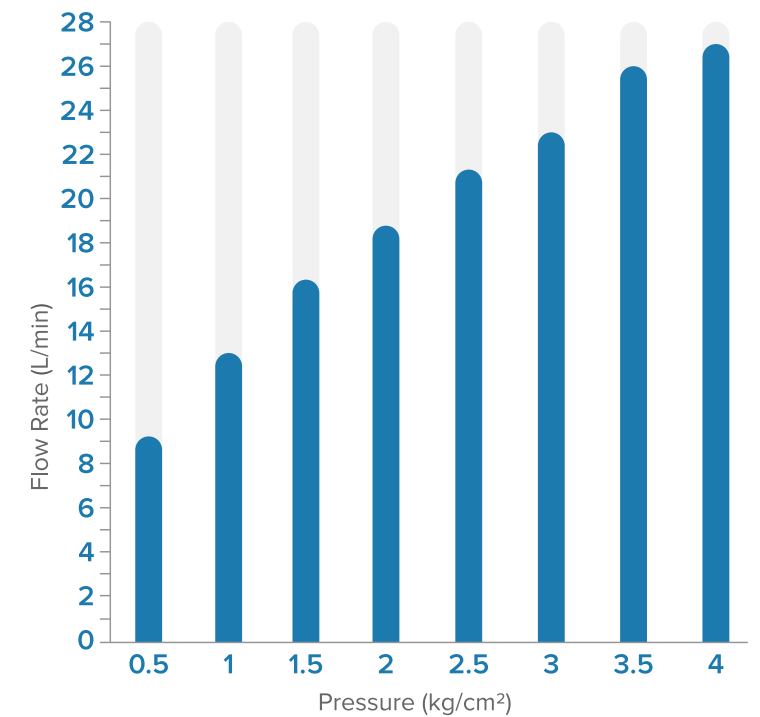

Water Flow Test	
Pressure (Bar)	Flow Rate (L/min)
0.5	9.1
1	13
1.5	16.2
2	18.8
2.5	21.2
3	23.2
3.5	25.3
4	27

Water Flow Test	
Pressure (Bar)	Flow Rate (L/min)
0.5	9.1
1	13
1.5	16.2
2	18.8
2.5	21.2
3	23.2
3.5	25.3
4	27

AT0802

M28X1.5 Quarter Turn Brass Concealed Cartridge



Technical Data	
Max. Turning angle	90°
Switching Torque	0.08-0.15N.m
Brass Composition Code	HPB59-3
Temp.	3-90°C
Connection Thread	M28x1.5
Bursting Test	35 Kg/cm2
Lifetime Test	>500000 Open and Close Cycles

100% High Air Pressure Testing On Every Cartridges Before Dispatch

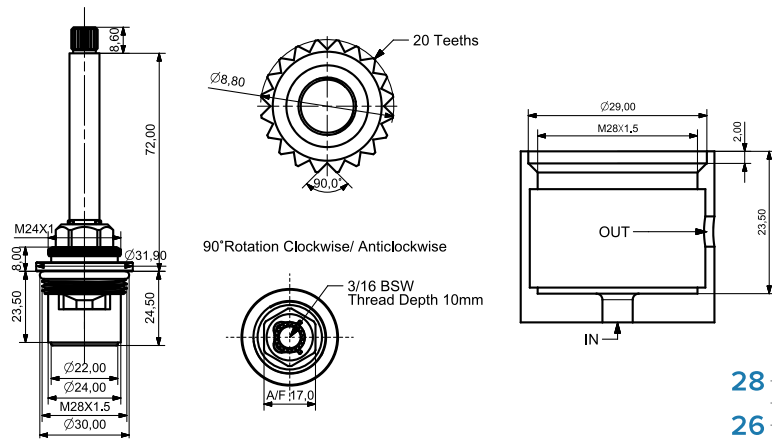

Water Flow Test	
Pressure (Bar)	Flow Rate (L/min)
0.5	9.1
1	13
1.5	16.2
2	18.8
2.5	21.2
3	23.2
3.5	25.3
4	27

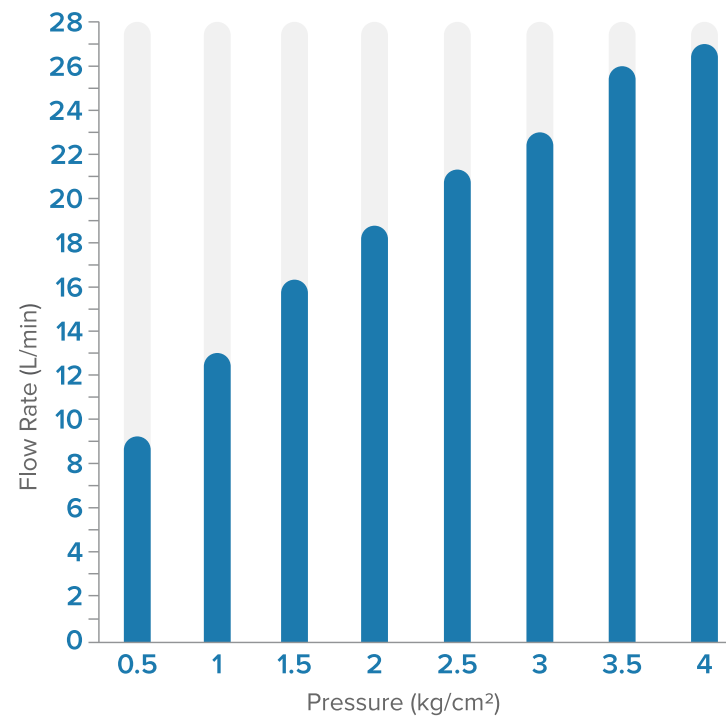

AT1001

M28X1.5 Quarter Turn Brass Concealed Cartridge



Technical Data	
Max. Turning angle	90°
Switching Torque	0.08-0.15N.m
Brass Composition Code	HPB59-3
Temp.	3-90°C
Connection Thread	M27x1.5
Bursting Test	35 Kg/cm2
Lifetime Test	>200000 Open and Close Cycles

100% High Air Pressure Testing On Every Cartridges Before Dispatch

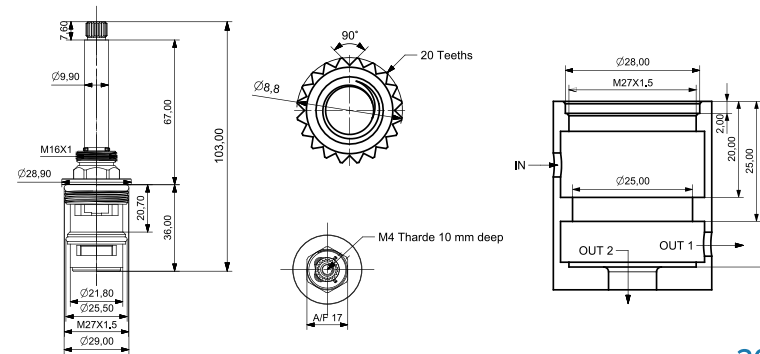

Static Pressure (kg/cm2)		Dynamic Pressure (kg/cm2)
High Pressure	Low Pressure	
8	0.2	3

Ceramic Disc	
Material	97% AL2O3
Hardness	≥1050Hv5
Flatness	≤0.6μm
Roughness	≤Ra0.25μm

Water Flow Test	
Pressure (Bar)	Flow Rate (L/min)
0.5	14
1	16.2
1.5	18.5
2	21
2.5	23.3
3	25.5
3.5	27.8
4	30.1

